

STRUCTURAL COMPONENTS:

- A) (2) 10' SIDERAILS
- B) (1) 3' WIDE HEADER WITH SIGN
- C) (1) 3' BOTTOM PLATE

HARDWARE LIST:

- (4) 1/2-13 x 3 BOLTS
- (4) 1/2" FLAT WASHERS
- (4) 1/2-13 2-WAY LOCK NUTS

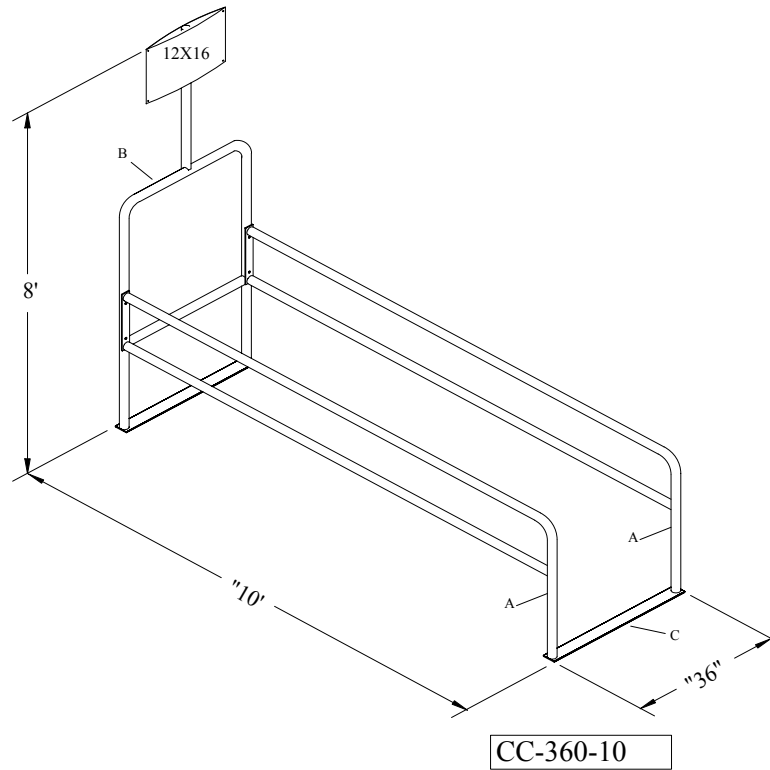

INSTRUCTIONS:

1. SELECT FLAT AREA TO PLACE CORRAL, AWAY FROM BUT NOT LIMITED TO CURBS & STORM DRAINS.
2. STAND HEADER FRAME (B) IN UPRIGHT POSITION. WHILE HOLDING IN PLACE. BOLT (1) SIDERAIL (A) USING (2) BOLTS, (2) NUTS & (2) FLAT WASHERS.
3. REPEAT THIS ON SECOND RAIL.
4. SLEEVE SIDE RAILS (A) OVER BOTTOM PLATE (C).
5. TIGHTEN ALL CONNECTIONS.

Ⓐ

C:\ACADWIN\DRAWINGS\INSTRUCT\CC360-10.DWG

| ITEM # | PART # | DESCRIPTION | MATERIAL | QTY. |
|---|--------|-------------|---|--|
| UNLESS OTHERWISE SPECIFIED: DIMENSIONS ARE IN INCHES | | | | |
| UNLESS OTHERWISE INDICATED: | | | | |
| REMOVE ALL BURRS AND BREAK SHARP EDGES. | | | | |
| TOLERANCES ON DIMENSIONS LOCATING BOLT HOLES AND FINISHED SURFACES SHALL NOT BE CUMULATIVE. | | | | |
| DRAWINGS FURNISHED BY NATIONAL CART INC. ARE PROPRIETARY DATA. THEIR USE DOES NOT GRANT BY IMPLICATION, ESTOPPEL, OR OTHERWISE ANY LICENSE UNDER THE RIGHTS OF NATIONAL CART INC. | | | TITLE CC-360-10 ASS'Y INSTRUCTIONS | |
| | | | FRACTION - 1/8 DECIMAL .XX ± .010 .XXX ± .010 .XXXX ± .002 ANGULAR - .2° | DRAWN JLG APPVD DATE 9/1/98 SCALE 1:20 SHEET 1 OF 1 REV A |
| | | | DWG NO: CC360-10 | |