

Food Bars

Ultra

Models 6UBR - 6 ft. (182 cm), 5UBR - 5 ft. (162 cm)
4UBR - 4 ft. (130 cm)

Features & Benefits

- Versatility, style and durability for self-service breakfast, lunch or dinner. Accommodates GN 1/1 Full or Fractional Size Food Pans up to 6" (15 cm) deep with Divider Bars.
- Quick access sliding doors on both sides offer convenient storage.
- Double-wall polyethylene construction provides extra strength, durability and reliability. Scratch-resistant textured exterior. Simple to clean - just wipe off.
- Thick foamed-in-place polyurethane insulation maintains food temperatures and holds ice cold for hours. Provides added structural strength.
- NSF listed threaded faucet drain with a standard hose hook-up provides quick draining and cleaning.
- Four each 5" (12.7 cm) swivel casters w/ brakes ensure easy maneuvering.
- Standard accessories include protective Sneeze Guard panel made from NSF listed material.
- Optional accessories include Tray Rails, End Tables, Divider Bars, Crock Holder, and Salad Bowl Holders.
- Non-electrical.
- Easy to assemble.
- Available in 15 colors.

Item No. _____

Specifier Identification No. _____

Model No. _____

Quantity _____



5UBR
(Shown with 1 each (SBH18) Salad Bowl Holder and 2 each (CPH3) Crock Holders)

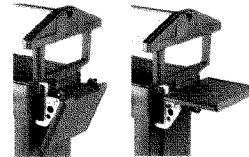

Optional End Table FBRTBL

Set Up Guide for Ultra Food Bars

Salad Bowls and Crock

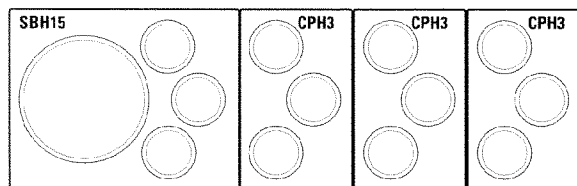
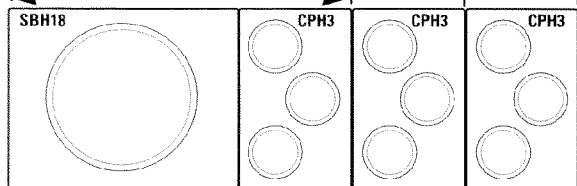
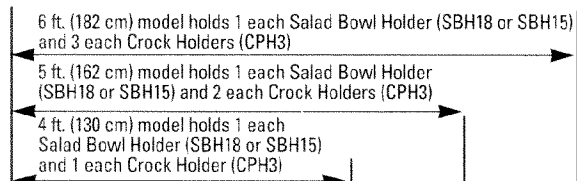

SBH18 - Holds 1 each 18" (45.7 cm) Salad Bowl
SBH15 - Holds 1 each 15" (38 cm) Salad Bowl & 3 each 1.5 qt. (1.4 L) or 2.7 qt. (2, 4 L) Crock
CPH3 - Holds 3 each 1.5 qt. (1.4 L) or 2.7 qt. (2, 4 L) Crock

Food Pans

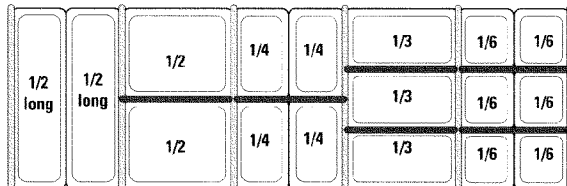
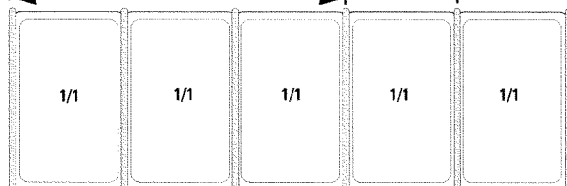
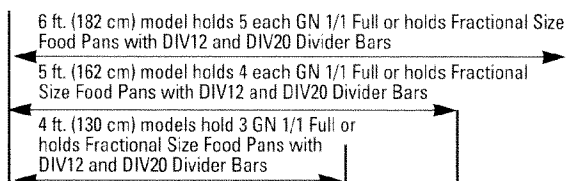

GN 1/1 Full Size Food Pans
← DIV20 20 1/2" (53 cm) Divider Bar

GN Fractional Size Food Pans
← DIV12 12 1/4" (32.5 cm) Divider Bar

Approvals



Food Bars

Ultra

Models 6UBR - 6 ft. (182 cm), 5UBR - 5 ft. (162 cm)
4UBR - 4 ft. (130 cm)

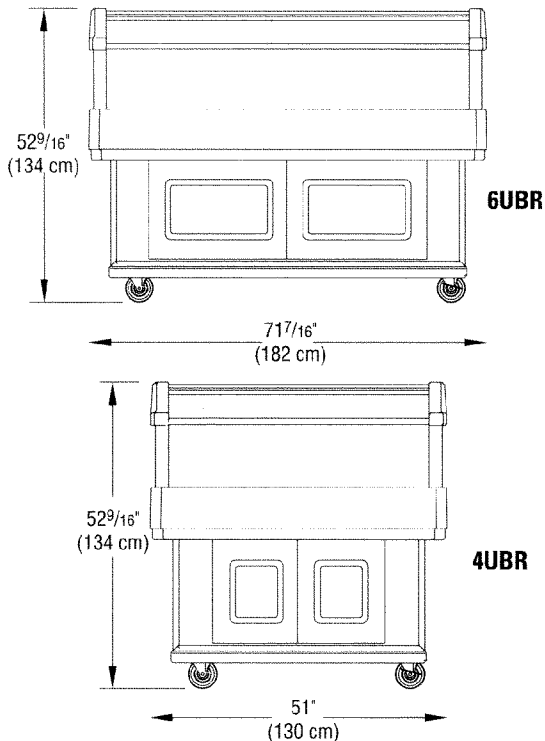

Item No. _____

Specifier Identification No. _____

Model No. _____

Quantity _____

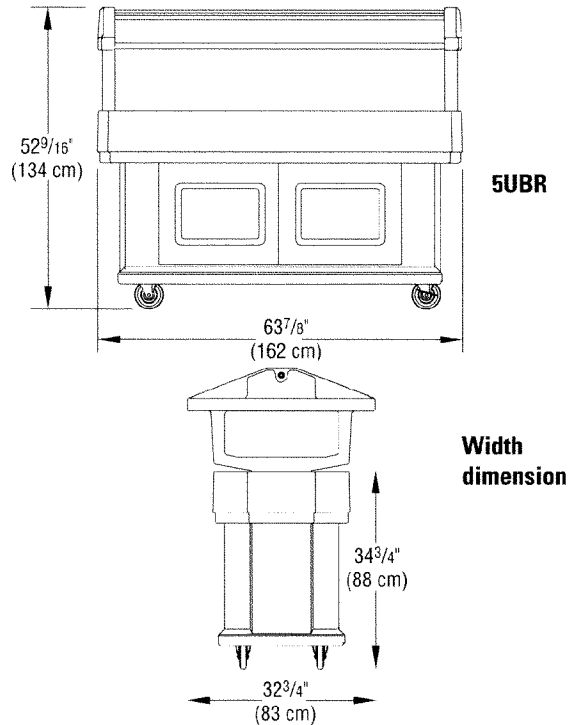

Specifications

Dimension Tolerance: +/- 1/4" (0,64 cm)

Code	Description	GN 1/1 Full Size Food Pan Capacity	Exterior Dimensions L x W x H	Case lbs./cube Kg/m ³
6UBR	6 ft. (182 cm) Ultra Food Bar	5	71 7/16" x 32 3/4" x 52 9/16" (182 x 83 x 134 cm)	170 (44.36) 77 (1,2)
5UBR	5 ft. (162 cm) Ultra Food Bar	4	63 7/8" x 32 3/4" x 52 9/16" (162 x 83 x 134 cm)	161 (39.50) 73 (1,1)
4UBR	4 ft. (130 cm) Ultra Food Bar	3	51" x 32 3/4" x 52 9/16" (130 x 83 x 134 cm)	143 (39.50) 65 (1,1)

Optional Accessories

- Tray Rails**
 - FBR6R (6 ft.) (182 cm)
 - FBR5R (5 ft.) (162 cm)
 - FBR4R (4 ft.) (130 cm)
- End Table**
 - FBRTBL
- 3-Crock Holder**
 - CPH3 (holds 1.5 qt. (1,4 L) and 2.7 qt. (2,4 L) crocks)
- Salad Bowl Holders**
 - SBH15 (holds one 15" (38 cm) bowl, 3 crocks)
 - SBH18 (holds one 18" (46 cm) bowl)
- Divider Bars**
 - DIV12 DIV20

Standard Colors

- Black (110)
 - Coffee Beige (157)
 - Navy Blue (186)
 - Green (519)
 - Granite Green (192)
 - Slate Blue (401)
 - Dark Brown (131)
 - Dusty Rose (400)
 - Hot Red (158)
 - Granite Red (193)
 - Brick Red (402)
 - Cold Blue (159)
 - Gray (180)
 - Granite Gray (191)
 - Granite Sand (194)
- Divider Bar:**
- White (148)
 - Clear (035)
- Crock Holder and Salad Bowl Holder:**
- White (148)

Architect Specs

The non-electrical portable foodservice food bar shall be a Floor Model Ultra Food Bar, Model..., manufactured by Cambro Mfg. Co., Huntington Beach, CA 92648 U.S.A. It shall be made of double-wall polyethylene and foam-injected polyurethane insulation. It shall have sliding doors on both sides for convenient storage. It shall have 4 each, 5" (12,7 cm) swivel casters w/ brakes. It shall hold optional accessories such as the Cambro Salad Bowl Holders (SBH18 and SBH15) and Crock Holder (CPH3) or a selection of GN Full or Fractional Size Food Pans with Divider Bars. The depth of the interior food

wells shall be 6 1/2" (16,5 cm). It shall be available with optional end tables and side tray rails. It shall include a sneeze guard and protective end panels. It shall have an NSF Listed threaded faucet drain with a standard hose hook up. It shall be available in 15 colors.

Approvals



CAMBRO

MANUFACTURING COMPANY
http://www.cambro.com

© 1999 Cambro Manufacturing Company 7601 Clay Avenue, Huntington Beach, California 92648-2219-U.S.A.