



Specialty Merchandisers



ACCENT SERIES™ Specialty Vertical Merchandisers
Shown with optional end bumpers and one additional shelf

HUSSMANN®

(GSVM-5272)

ACCENT SERIES™ Specialty Vertical Merchandisers

GSVM-4060, GSVM-4072, GSVM-5272 Self-Contained, Medium Temperature Displays Produce, Dairy, Beverages and Deli Products . . . Salads, Pizza, Fresh Entrees, Wine, Cheese, and Floral

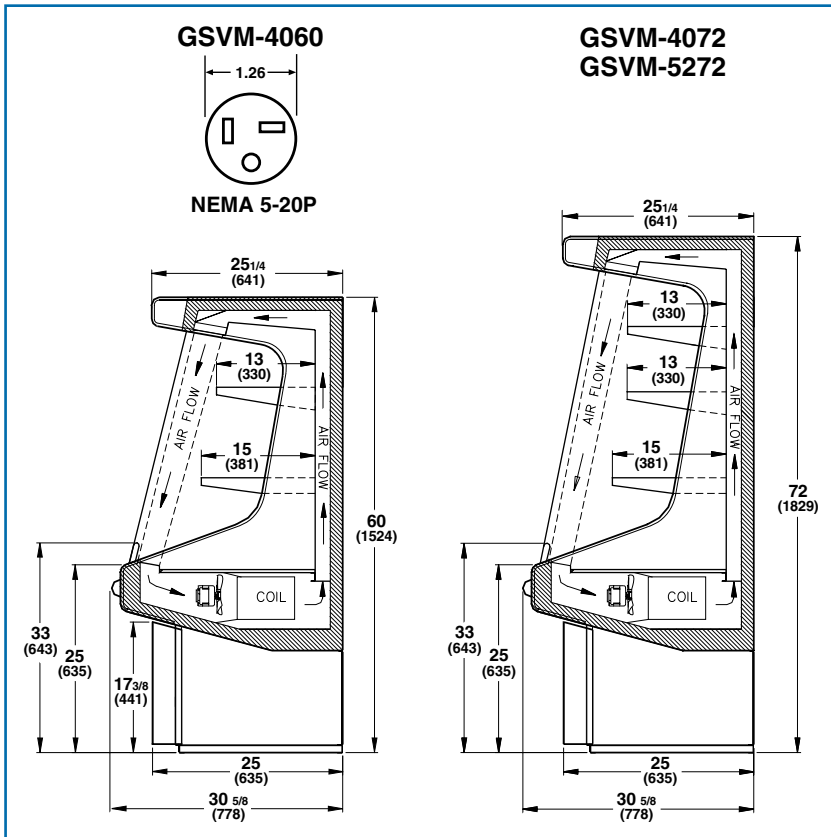

Design

The contemporary styling of the ACCENT SERIES places maximum attention on merchandising. A softer, rounder design featuring as standard a Kings Grey exterior color and Slate recessed base. The narrow canopy and plexiglass side panels increase product visibility. All ACCENT SERIES merchandisers have the same contour and line up together to create extended product displays.

Merchandising

Maximize display flexibility with a choice of three models...increase product facings with the GSVM-5272 or create an end cap spot display with the GSVM-4060 or GSVM-4072. The large, open front allows easy access to display levels for merchandising or shopping. Canopy and shelf lighting add more product illumination throughout the merchandiser.

Construction

Easy to clean interior and exterior. Easy to service slide out condensing unit. CFC-Free foamed-in-place urethane insulation. Timer controlled automatic defrost. Electric condensate removal. Thermometer. Two-position lighted cantilever shelves.

Refrigeration

Models GSVM-4060 and GSVM-4072 have front air intake and discharge. The GSVM-5272 has front air intake and rear air discharge which requires a 5" minimum open space behind the back of the case. State-of-the-art honeycomb discharge air system assures even temperature throughout...with maximum efficiency. Adjustable temperature control.

Warranty

Five years against insulation failure or leaks in insulated area. Five years against failure of compressor. One year against defective materials or faulty workmanship, including labor.

Model	Exterior Dimensions			Nominal H.P.	Refrig.	Hz/Ph	Electrical			Power Cord
	L	D	H				Volts	Run Amps	Fuse Amps	
GSVM-4060	40"	30 5/8"	60"	3/4	R-134a	60/1	115	15	20	Yes*
GSVM-4072	40"	30 5/8"	72"	3/4	R-134a	60/1	115	20	25	No
GSVM-5272	52"	30 5/8"	72"	3/4	R-404A	60/1	115	23.5	30	No

*Requires 20-amp receptacle (NEMA 5-20P).

Optional Accessories

- Shelving and Merchandising Inserts
- Choice of exterior colors
- Wrap around Bumper
- Stainless Steel Exterior
- Legs
- Night Cover (Standard in GSVM-5272)
- Locking Security Cover
- Remote Application
- Cross Bar and Hook Display
- Casters

NOTE: For optimum performance, these models are designed for use in air-conditioned stores where temperature and humidity are maintained at 75°F and 55% R.H. Locate case away from direct sunlight, rapid air currents and extreme temperature changes.

We reserve the right to change or revise specifications and product design in connection with any feature of our products. Such changes do not entitle the buyer to corresponding changes, improvements, additions, or replacements for equipment previously sold or shipped.



HUSSMANN®

Hussmann Web Site: <http://www.hussmann.com>

Hussmann Corporation
140 East State Street
Gloversville, NY 12078
(518) 725-0644
(800) 753-7790
Fax: (518) 725-3801